



General:

The electrical submersible pump (ESP) system is intended to lift large volumes of fluids in an efficient and cost-effective manner. The system can be divided into two main equipment groups, located downhole and at the surface, and connected to each other by a power cable.

The need to protect people and the environment, while maximizing operational functionality of the surface equipment led to the development of Skids for this specific application.

Main Components

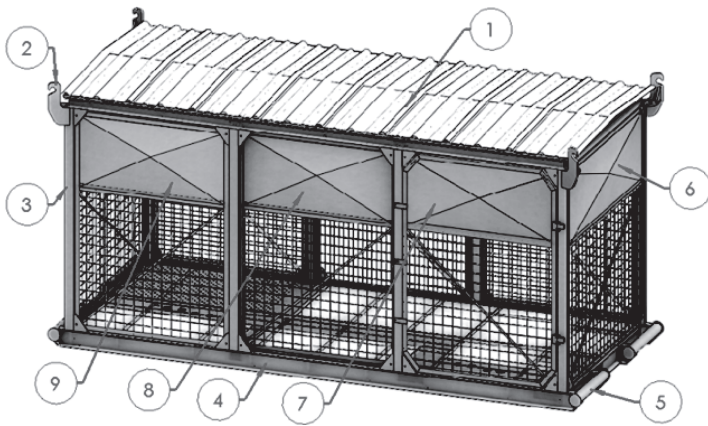

N°	DESCRIPTION	MATERIAL
1	COVER	ZINC PLATE, SQUARE PIPE FRAME
2	LIFTING LUGS	HR SHEET
3	STRUCTURAL COLUMNS	C-PROFILE
4	SIDE BEAMS	IPF PROFILE
5	DRAGGING PIPES	ROUND PIPE
6	SIDE PANEL	ANGLE, MESH, SHEET
7	HINGED DOOR	STEEL, ANGLE, MESH, SHEET, HINGES
8	SLIDING DOOR	ANGLE, MESH, C-14 SHEET, RAIL AND ROLLERS
9	FRONT PANEL	ANGLE, MESH, SHEET

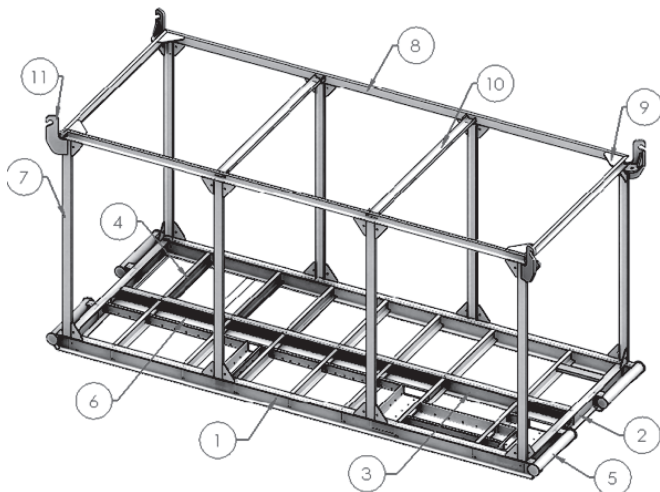

N°	DESCRIPTION	MATERIAL
1	SIDE BEAMS	IPE PROFILE
2	BASE ENCLOSURE	IPE PROFILE
3	MAIN BEAM	IPE PROFILE
4	BASE SUPPORT	C-PROFILE
5	DRAGGING PIPES	SCH 40 ROUND PIPE
6	SUMPS	HR SHEET
7	STRUCTURAL COLUMNS	C-PROFILE
8	UPPER FRAME	C-PROFILE
9	PERIMETER REINFORCEMENTS	HR SHEET
10	FRAME REINFORCEMENTS	C-PROFILE
11	LIFTING LUGS	HR SHEET



Skid Magnetron:

The Magnetron Skid has been specifically designed for surface equipment used in electrical submersible pumping of oil, resulting in a perfectly matched system to address and meet the technical and economic needs of the oil industry.

Skid dimensions / Voltages (kVA):

LENGTH	WIDTH	HEIGHT	KVA	RO OF OPTIONS	LIFTING OPTIONS	ACCESS OPTIONS
6 y 7 m	2,4m	2,3 - 2,5m	130-260- 400-520- 750.	Fixed or sliding	Top lifting lugs	Front and back

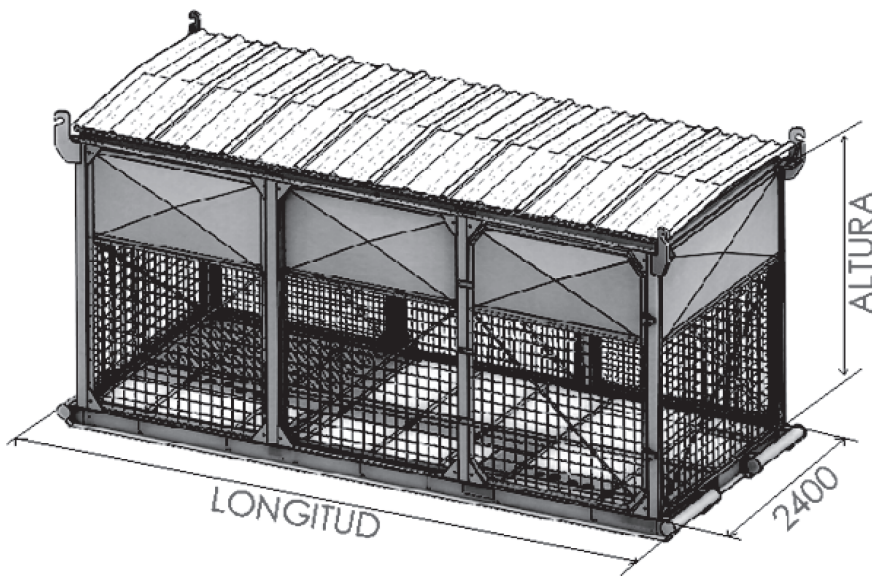

*The dimensions indicated here are estimates and are not to be used for the design of civil works.

Typical skid distribution for 3 devices

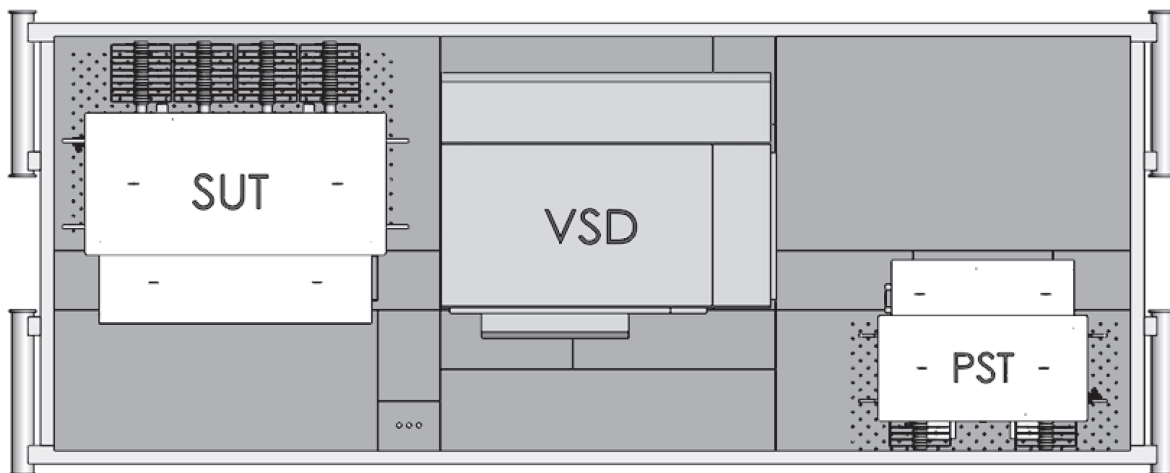

TOP VIEW